

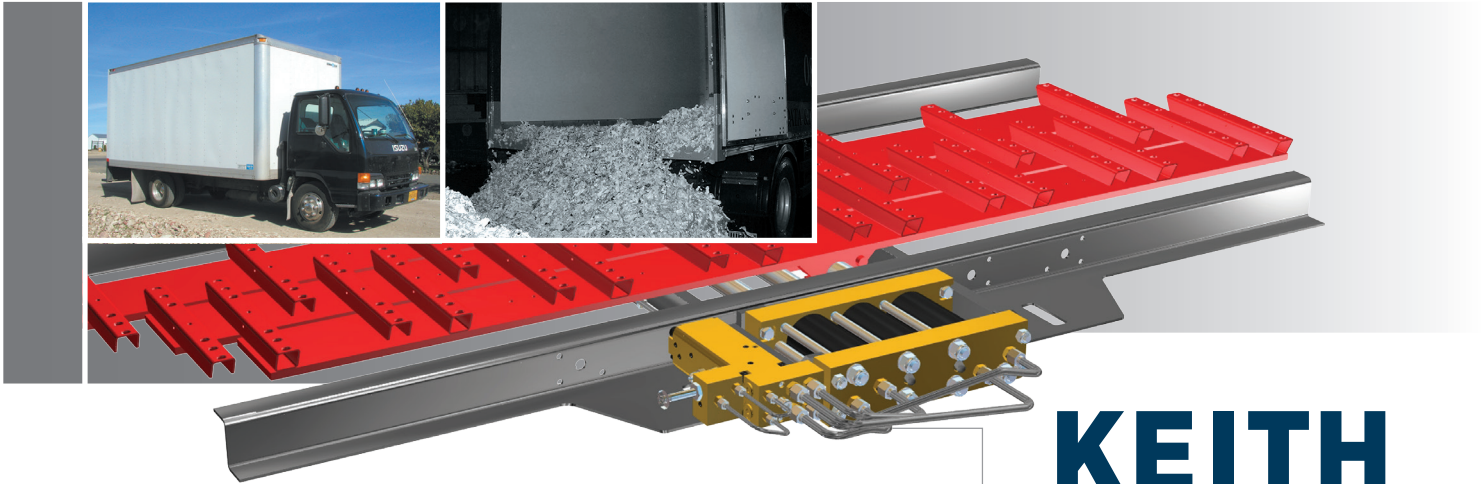

THE KEITH® M-SERIES DRIVE



THE KEITH® M-SERIES DRIVE

The same reliable KEITH technology in a smaller drive unit. Designed for lighter loads, such as curbside collection, document shredding and wood chips. Quick and easy installation. We supply the floor, you supply the rest.

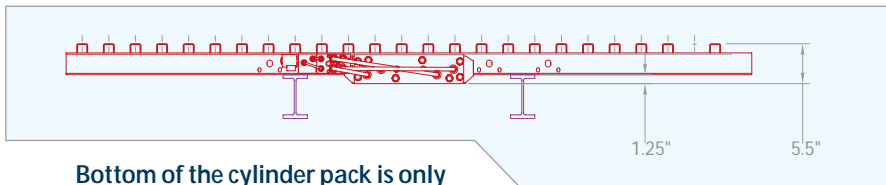

Bottom of the cylinder pack is only 1.25 inches below the support rail.

- The lowest profile 2-way system available.
- Durable and dependable construction.
- Compact design.
- Low maintenance.
- Fast unloading speed.
- Aluminum components protected from corrosion.
- Easily removable switching valve and cylinder pack for service.
- Interchangeable cylinder packs and cross-drives.
- Externally mounted valve assemblies are easy to access.



KEITH Manufacturing Co.

1.800.547.6161

www.keithwalkingfloor.com

KEITH

MANUFACTURING CO

IDEAL FOR INSTALLATION IN

- Small Trucks
- Small Trailers
- Drop-Off Containers
- Small Bins
- Roll-Off Boxes

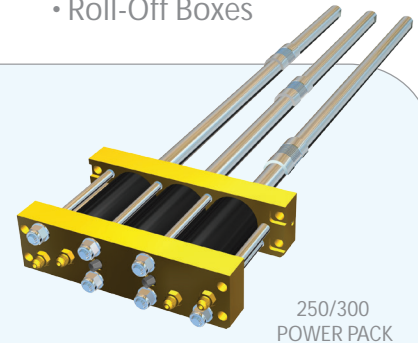

250/300
POWER PACK

Switching valve and cylinder pack are easy to remove for service.

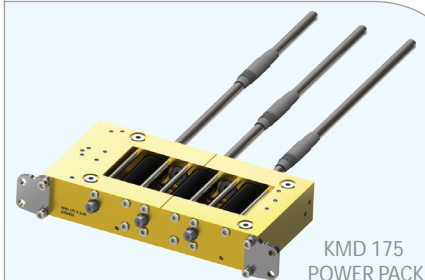

KMD 175
POWER PACK

KMD-175

KMD-250

KMD-300

Hydraulic Drive Unit Specifications

	KMD-175	KMD-250	KMD-300
Cylinder Bore	1.75" [44 mm]	2.5" [63mm]	3.0" [76mm]
Cylinder Stroke	4.0" [101 mm]	5.0" [127mm]	5.0" [127mm]
Maximum Working Pressure	3000 PSI [210 bar]	3,000 PSI [206 bar]	3,000 PSI [206 bar]
Maximum Pump Flow	5.5 g/min [21 l/min]	11 g/min [42 l/min]	15 g/min [56 l/min]
Load Capacity	5 ton [4536kg]	8 ton [7257kg]	16 ton [14515kg]
Floor Speed*	0-8 ft/min [2.5m/min]	0-8 ft/min [2.5m/min]	0-8 ft/min [2.5m/min]

* Unload/Load times may vary with length of trailer, material type, or other environmental variables.

FEATURES

Drive Design

- Cross-drives are supported on plastic bearings, strengthening the entire drive area.
- Center frame drive unit prevents possible damage to trailer structure.
- Compact design for easy installation and service.
- Designed for installation in units with 3.0" cross members.
- Easily adapted for other cross member heights.
- KMD 250 can be upgraded to KMD 300.

Superior Cylinder Design and Construction

- Case hardened, chrome rods provide superior wear.
- High quality piston seals and wear rings extend cylinder life.

Poppet Switching Valve

- Controls the movement of the floor.
- Patented design provides excellent resistance of dirt and foreign material.
- Requires less maintenance and repair than other systems.

Options

- Solenoid valve allows remote on/off and load/unload functions.
- Manual on/off and load/unload are always available.
- In-line pressure filter to reduce oil contaminants.
- 18, 21 & 24 slat combinations.



Patents Pending and Applied For.

Drive Features

Overall Height	5.5" [140mm]
Maximum Length	60.5" [1537mm]
Weight (24 slat system)	580 lbs * [263kg]*

* Does Not Include Flooring.

KEITH

MANUFACTURING CO

KEITH Manufacturing Co. WORLD HEADQUARTERS

Madras, OR USA
(541) 475-3802
sales@keithwalkingfloor.com

Canada

canadasales@keithwalkingfloor.com

México

kmc_mexico@keithwalkingfloor.com

Australia

ausales@keithwalkingfloor.com

Europe

eurosales@keithwalkingfloor.com

www.keithwalkingfloor.com