

al it

lu inu looring

KEITH Mfg. Co.
World Headquarters
800-547-6161
541-475-3802
541-475-2169 fax

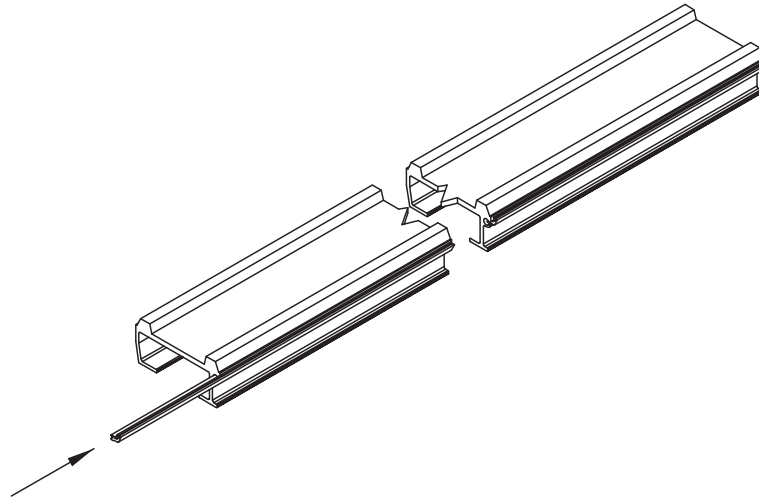

www.keithwalkingfloor.com



Installation Manual

Original Instructions

©2016 KEITH Mfg. Co. KEITH, KEITH logo and WALKING FLOOR are registered trademarks of KEITH Mfg. Co. Equipment manufactured by KEITH Mfg. Co. is protected by numerous patents both domestic and foreign. Manufactured under license.

IMPORTANT NOTE:

WELD ON WEAR STRIPS AND FILLER PLATES BEFORE INSTALLING THE SEAL.

STEP 1:

Begin by placing the bundle of floor slats on four equally spaced sawhorses. The sawhorses must be strong enough to support the weight of the floor slats. Remove the banding from the bundle.

STEP 2:

Inspect the ends of the floor slats. De-burr the seal groove. Chamfer the outside edge of the floor slat opposite the seal groove. De-burr and chamfer both ends of the floor slats (See Diagram Below).

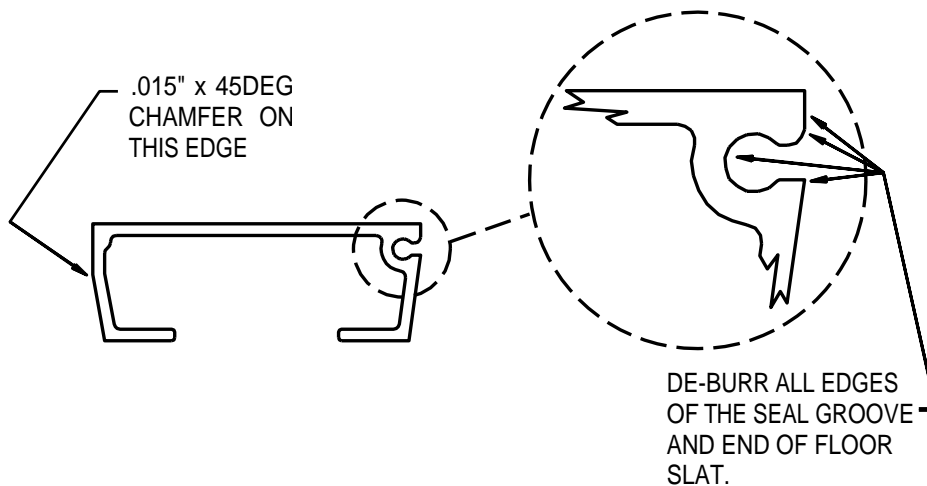

STEP 3:

Stand each slat up on one side, so that the seal groove is facing upward for the rest of the process.

STEP 4: Trim the ball of the floor seal at a 45° angle at bottom ends. The angle on the seal pushes the adhesive into the seal groove. Pull the floor seal into the floor slat. The open side of the "Y" must be pointed toward the top of the floor slat. Pull the seal to the proper distance from the end of the slat as shown in the table on the next page. Cut the seal off flush with the other end of the slat. (Trim Ball at 45) Do this with the entire bundle of slats.



Seal Color	Slat Length	Seal Length	Stretch
Black	51' 5"	49' 9"	20"
Gray	51' 5"	50' 7"	10"
Black	46' 5"	44' 11"	18'
Gray	46' 5"	45' 8"	9"
Black	43' 5"	42'	17"
Gray	43' 5"	42' 8.5"	8.5"
Black	38' 5"	37' 2"	15"
Gray	38' 5"	37' 9.5"	7.5"
Black	30' 5"	29' 5"	12"
Gray	30' 5"	29' 11"	6"
Black	25' 5"	24' 7"	10"
Gray	25' 5"	25'	5"
Black	18' 5"	17' 9"	8"
Gray	18' 5"	18' 1"	4"
Blue	All	Flush	Flush

STEP 5:

Apply a 1/8" diameter bead of Sikaflex®-221 adhesive sealer in the exposed seal groove (From the end of the seal to the end of the slat). Hold the caulking gun at a 60 degree angle to the floor slat. (Push the bead - do not pull - when using a manual applicator. If using a Sikaflex® air applicator, pull the bead.)



NOTE: The bead should be 2" long for the BLUE SEAL.

Repeat the last step, throughout the entire bundle of slats.



STEP 6:

Pull the seal flush with the end of the slat. When pulling the seal through the bead of adhesive, make sure to pull the seal outward from the slat as well as toward the end.



Repeat the last step, throughout the entire bundle of slats.



STEP 7:

Once all of the seals are pulled to the ends of the slats, place an anchor screw into the recess in the ball of the seal and tighten it in place. (DO NOT OVERTIGHTEN THE ANCHOR SCREW) After the screw is installed into the end of the slat, push the end of the seal against the slat everywhere the Sikaflex® has been installed.



Repeat the last step, throughout the entire bundle of slats.



STEP 8:

Move to the other end, apply Sikaflex® across the remaining open areas of the slats. See step 5 for more details.



STEP 9:

Stretch the seal flush with the other end of the slat, making sure to pull outward on the seal as you pull it back.



STEP 10:

While holding the seal flush to the end of the slat, install an anchor screw in each of the seals to hold them in place. **DO NOT OVER TIGHTEN THE ANCHOR SCREW. ALLOW THE ADHESIVE TO DRY BEFORE INSTALLING THE SLATS.**



STEP 11:

Apply three additional beads of Sikaflex® behind the seal. The additional beads of Sikaflex® should be at least 24" long and should be located at 1/4 slat length; 1/2 slat length; and 3/4 slat length. The additional beads are to be applied after the seal is installed.



AFTER APPLICATION OF SIKAFLEX® PUSH SEAL AGAINST SLAT AT EACH AREA THAT SIKAFLEX® IS APPLIED.

Sikaflex®

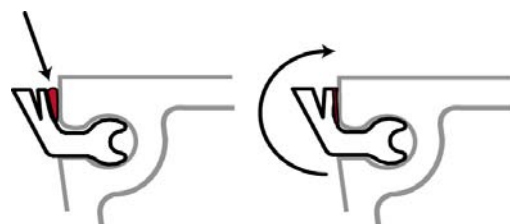

OPTIONAL: (RECOMMENDED FOR FOREST AND AGRICULTURAL PRODUCTS)

After applying the Sikaflex® and attaching the ends of the seals to the slats, apply an additional bead of Sikaflex® behind the full length of the floor seal. This will reduce “rippling” and create a more positive seal. Allow the adhesive to dry before installing the slats.



TIP:

By placing your finger between the seal and the slat, before you place the sealer gun into the gap, you will be able to run a continuous bead the remaining length. You may also want to trim the end of the gun to an angle that is comfortable for you to use. Repeat the last step, throughout the entire bundle of slats.



OPTION#2: (RECOMMENDED WHEN UNLOADING CHIPS AT A PULP MILL)

Once all seals have been installed and all the Sikaflex® has been applied, you may want to trim the seal as shown to reduce the possibility of getting plastic in your chips while unloading.

Gently place a sharp blade at the point of the seal where it begins the "Y" shape.

(See Diagram Below)

Slice gently being careful not to cut any deeper into the seal. You will need to continue this approximately 10" from the end of the slat.



Once you have reached 10", do not stop the cut. Instead taper the cut away from the slat so that there is a smooth transition from where the outer branch of the "Y" is removed to where it still exists. Repeat this step for all the slats at one end only. The end of the slats with the trimmed seal should be installed at the rear of the trailer.



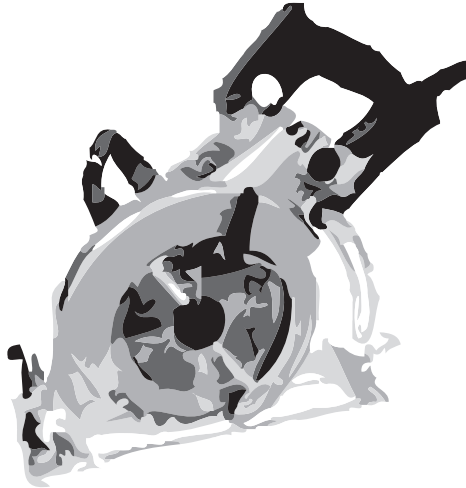

KEITH® Instructions to trim a floor slat (after the floor seal has been installed)

Use approved eye and body protection when trimming floor slat and installing seal.

Instructions to trim a floor slat to length after the floor seal has been installed:

STEP 1:
Cut the floor slat to the required length. If there are wear strips or filler strips installed on the slat, it is recommended to cut off the opposite end. The wear strips and front filler strips must be replaced, if removed by shortening the floor slat. Be careful not to damage the floor seal.



STEP 2:
Slide the loose end of the floor seal away from the end of the slat, as far as possible.



STEP 3:
Inspect the ends of the floor slat. De-burr the seal groove. De-burr and chamfer both ends of the floor slats. (See Diagram Below)

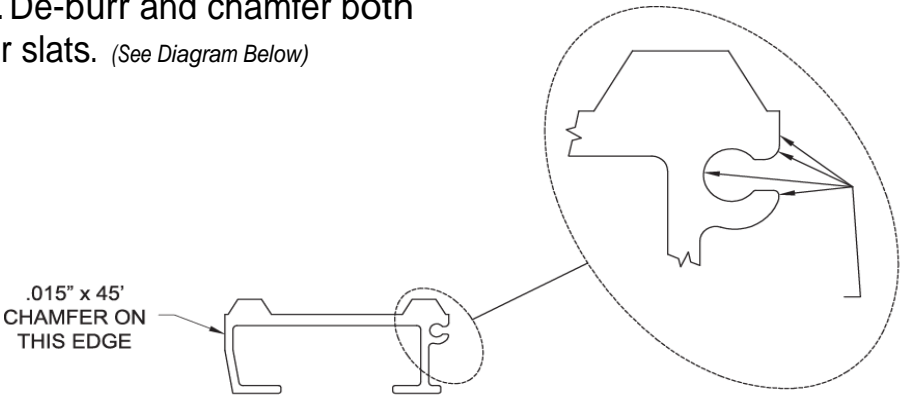

STEP 4:

If wear strips or filler strips were removed during cutting the slat, weld on wear strips or filler strips. Shield the floor seal from weld splatter. Use a heat sink to prevent damage to the floor seal.

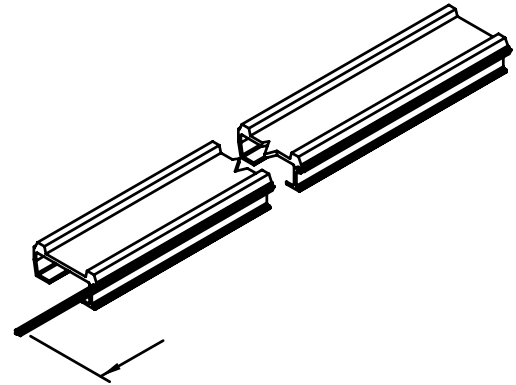

STEP 5:

Pull seal out the end of the floor slat 5" - 6". Pull the seal out sideways from the seal groove. Pull the seal out approximately 18" from the end of the floor slat.

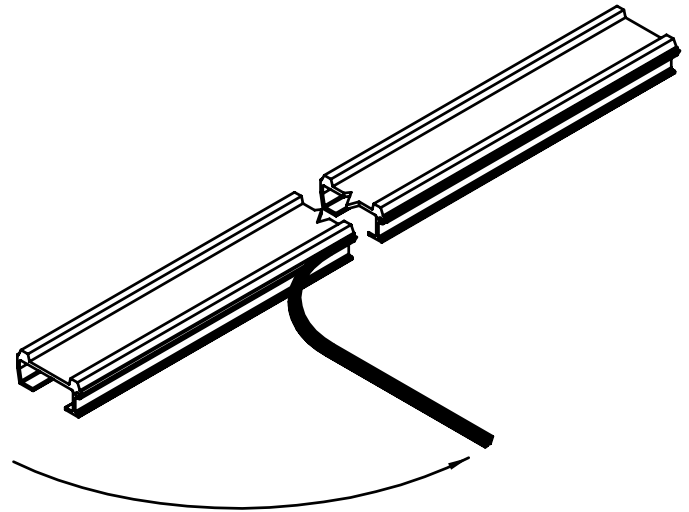

STEP 6:

Trim the ball of the floor seal at a 45 degree angle. The angle on the seal pushes the adhesive into the seal groove.

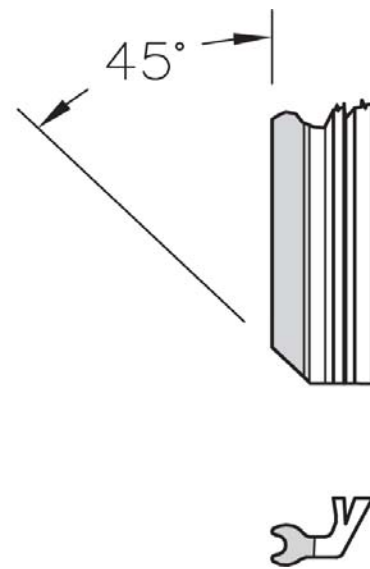
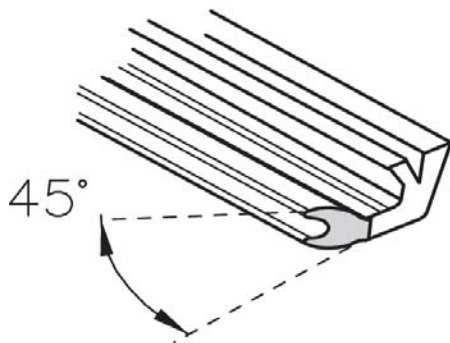

STEP 7:

Apply a 1/8" diameter bead of Sikaflex®-221 adhesive sealer in the exposed seal groove. (From the end of the seal to the end of the slat.) Hold the caulking gun at a 60 degree angle to the floor slat. (Push the bead - do not pull).

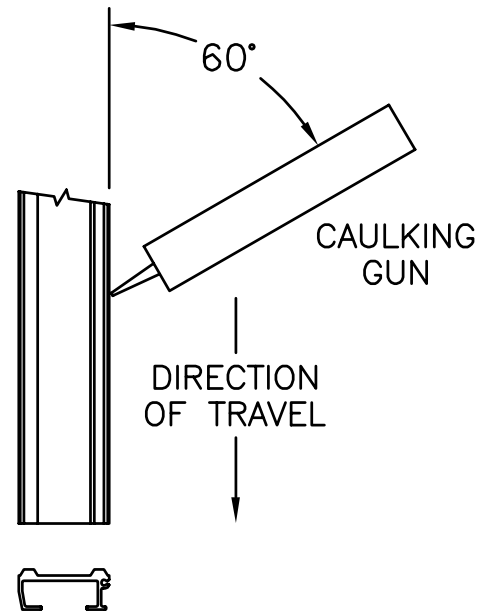
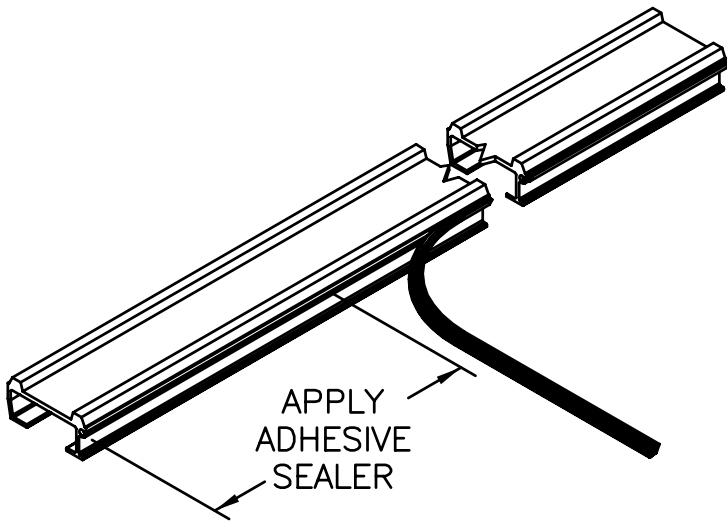

STEP 8:

Pull the floor seal toward the end of the floor slat until the seal will feed back into the seal groove. Place the seal back into the seal groove.

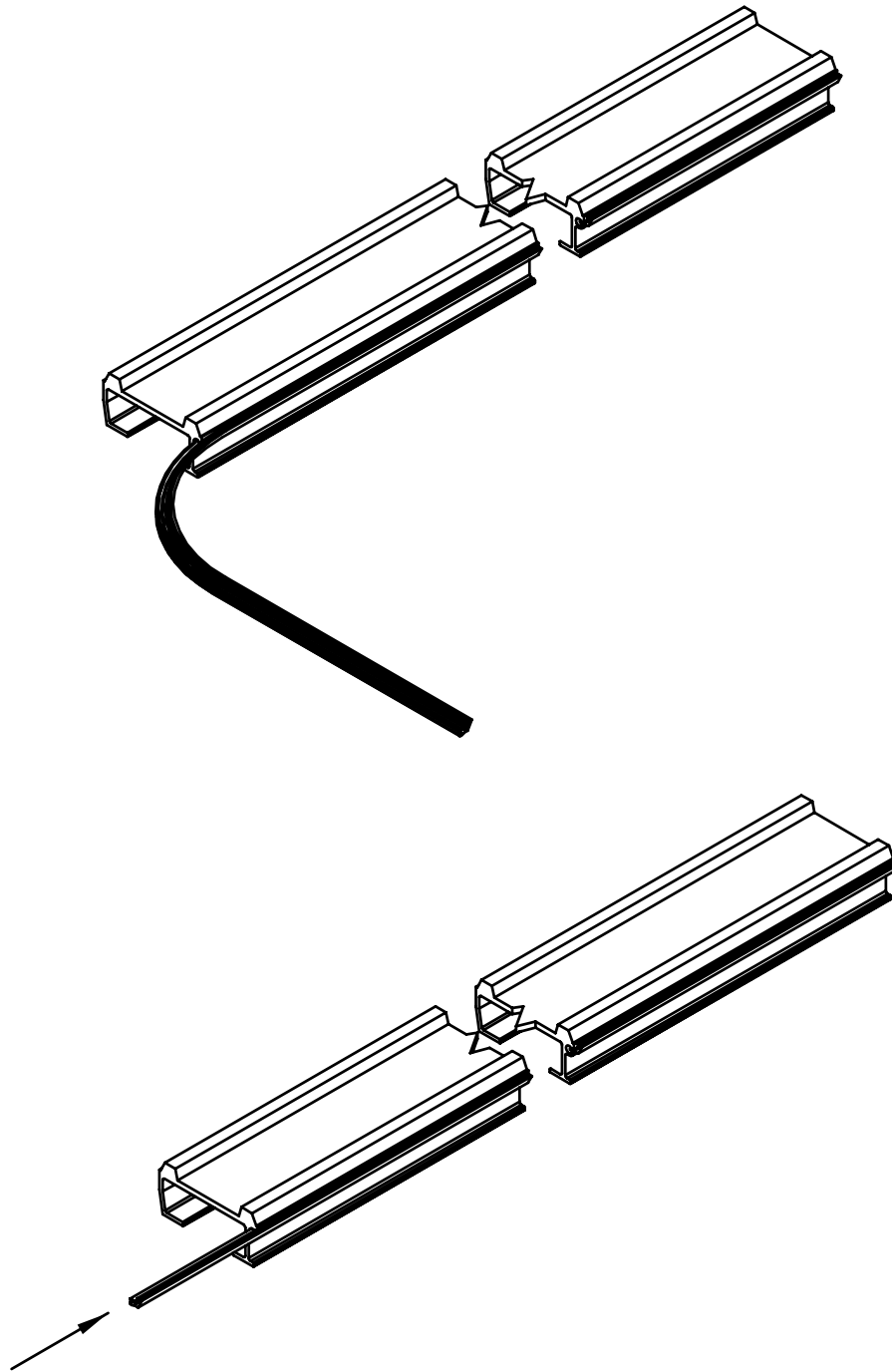

STEP 9:

Press the loose end of the floor seal into the floor slat.

STEP 10:

Apply a bead of Sikaflex®-221 adhesive into the exposed seal groove. **Push seal against slat after installing Sikaflex® behind seal.**

STEP 11:

Stretch the seal flush with the end of the slat, making sure to pull outward on the seal as you pull it back. While holding the seal flush to the end of the slat, install an anchor screw in each of the seals to hold them in place. **DO NOT OVER TIGHTEN THE ANCHOR SCREW. ALLOW THE ADHESIVE TO DRY BEFORE INSTALLING THE SLATS.**

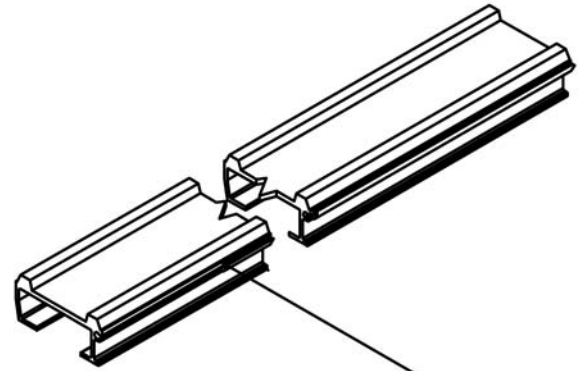

PUSH THE FLOOR SEAL INTO THE FLOOR SLAT

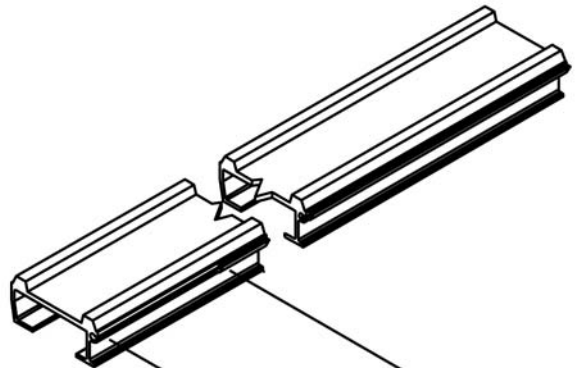

APPLY ADHESIVE SEALER

